

THERMAL MANAGEMENT PRODUCTS CATALOG

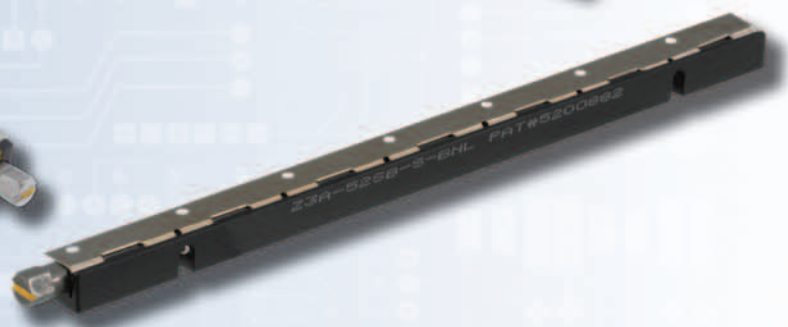
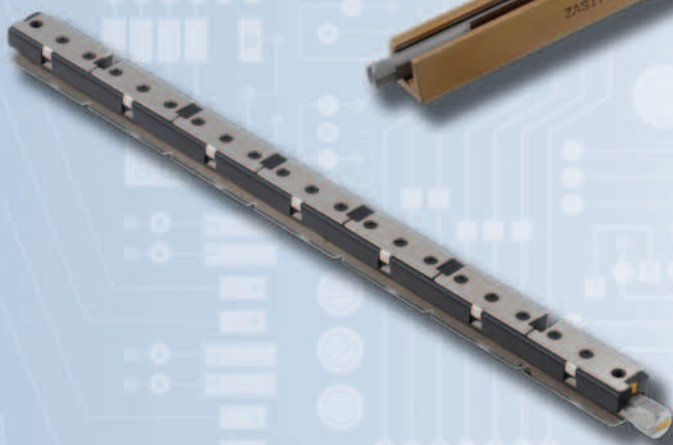
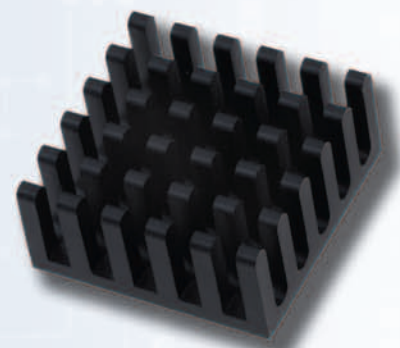
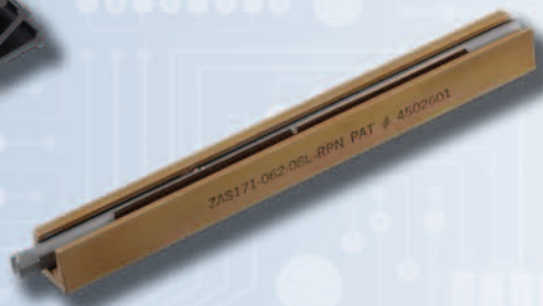
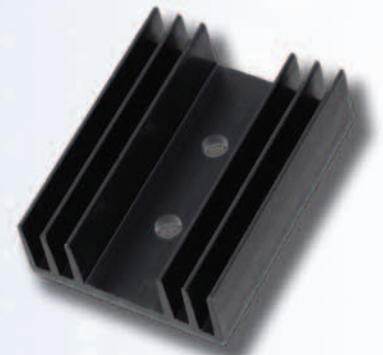
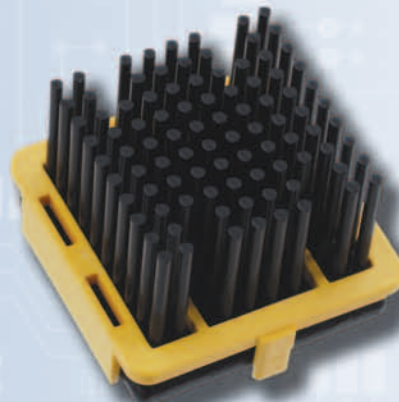
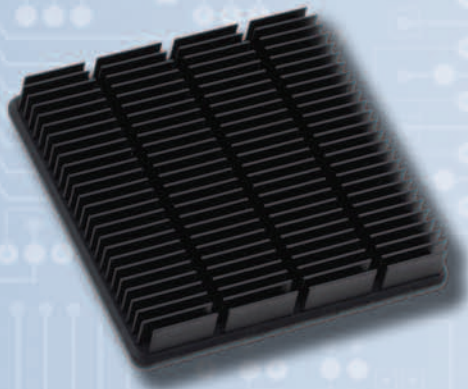

TABLE OF CONTENTS

	<u>PAGE</u>
<i>ADHESIVE PEEL AND STICK HEAT SINKS</i>	3
<i>FORGED HEAT SINKS WITH PLATE FINs</i>	4
<i>FORGED HEAT SINKS WITH PIN FINs</i>	6
<i>CLIP AND TAPE STYLES</i>	7
<i>ZIF STANDARD CIRCUIT BOARD RETAINERS</i>	8
<i>ZIF III CIRCUIT BOARD RETAINERS</i>	10
<i>ZIF PRIME CIRCUIT BOARD RETAINERS</i>	12
<i>THERMAL LINKS FOR TO-5, TO-8 AND TO-18 TRANSISTORS</i>	14
<i>ADDITIONAL EXTRUDED PRODUCTS FOR TO-126, TO-202, TO-218 AND TO-220 TRANSISTORS</i>	15
<i>HEAT SINKS FOR METAL AND PLASTIC CASE, CASE-MOUNTED SEMICONDUCTORS</i>	16
<i>BOARD-MOUNTED AND VERTICALLY MOUNTED HEAT SINKS WITH BOARD-MOUNTED TABS</i>	17
<i>BOARD AND VERTICALLY MOUNTED HEAT SINKS</i>	18

CORPORATE PROFILE

CTS Electronic Components is a division within CTS Corporation (NYSE: CTS), a leading designer and manufacturer of electronic components and a provider of electronics manufacturing services to OEMs in the automotive, communications, defense and aerospace, industrial and medical markets.

In 1997, CTS acquired Dynamics Corporation of America, the parent corporation of the former International Electronic Research Corporation (IERC). Since then, CTS has continued to develop, manufacture and market a quality line of standard and custom thermal management products and rugged circuit board retainers for the electronics and military industries.

Through the years, CTS has fine-tuned its business systems to accommodate each customer's unique design and lead-time requirements.

Choosing CTS as a supplier adds value by providing expert technical assistance during the design stage, quick prototype turnaround and dedicated manufacturing throughout the application lifecycle. CTS thermal management products are sold and supported through the CTS global network of manufacturer representatives, distributors and research facilities. We welcome the opportunity to serve you. Please visit us at www.ctscorp.com/components and then click on - Heat Sinks/Thermal Management Solutions and Circuit Board Retainers.

ADHESIVE PEEL AND STICK HEAT SINKS

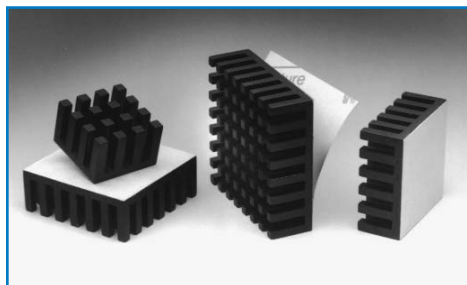

- With pre-applied adhesive, just peel off the release liner and press onto the component
- Reduces assembly costs; no more messy adhesives or greases required
- Excellent mechanical bond
- Thermally optimized pin fin
- Omnidirectional
- Adhesive shear strength at 100°C is 36psi (a one inch square heat sink would require a 36lb. force to remove heat sink)
- Applicable for BGA, PGA, PLCC, and QFP packages

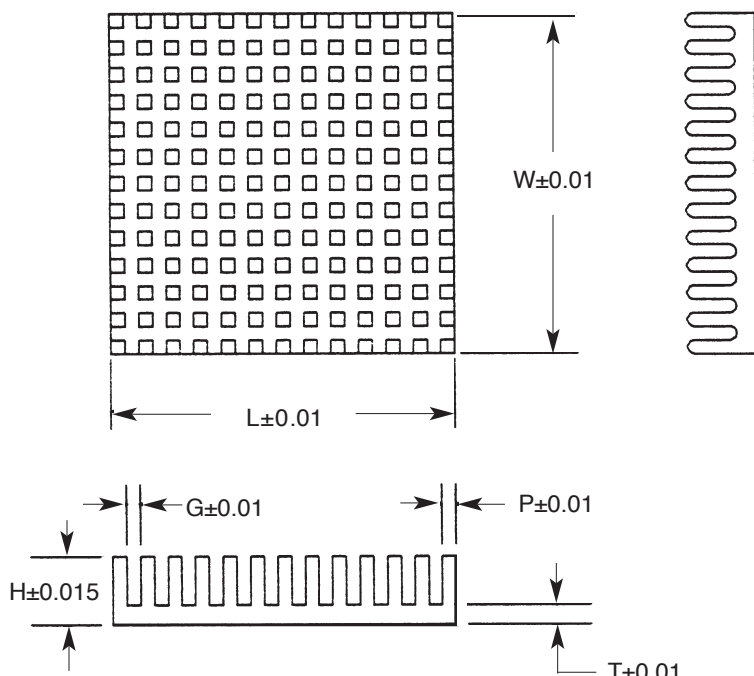

HEAT SINK SPECIFICATIONS

HEAT SINK PART NUMBER***	SIZE				PIN FIN CONFIGURATION			THERMAL RESISTANCE CASE TO AMBIENT* °C/WATTS	
	(W)	(L)	(H)	T	P	G	FIN MATRIX	NATURAL CONVECTION**	FORCED CONVECTION @ 400 LFPM
BDN09-3CB/A01	0.91	0.91	.355	.09	.069	.072	7x7	26.9	9.6
BDN09-6CB/A01			.605	.10	.132	.128	4x4	24.5	7.7
BDN10-3CB/A01	1.01	1.01	.355	.09	.083	.072	7x7	26.4	8.0
BDN10-5CB/A01			.555	.10	.111	.114	5x5	20.8	6.3
BDN11-3CB/A01	1.11	1.11	.355	.09	.076	.072	8x8	20.9	7.2
BDN11-6CB/A01			.605	.10	.119	.128	5x5	18.5	5.7
BDN12-3CB/A01	1.21	1.21	.355	.09	.060	.081	9x9	19.6	6.8
BDN12-5CB/A01			.555	.10	.105	.114	6x6	16.5	5.2
BDN13-3CB/A01	1.31	1.31	.355	.09	.074	.081	9x9	16.1	6.0
BDN13-5CB/A01			.555	.10	.125	.114	6x6	14.9	4.7
BDN14-3CB/A01	1.41	1.41	.355	.09	.067	.081	10x10	16.2	5.6
BDN14-6CB/A01			.605	.10	.128	.128	6x6	13.1	4.2
BDN15-3CB/A01	1.51	1.51	.355	.09	.062	.081	11x11	15.1	4.5
BDN15-5CB/A01			.555	.10	.118	.114	7x7	11.9	3.8
BDN16-3CB/A01	1.61	1.61	.355	.09	.072	.081	11x11	13.5	4.5
BDN16-6CB/A01			.605	.10	.119	.128	7x7	10.6	3.5
BDN17-3CB/A01	1.71	1.71	.355	.09	.065	.072	13x13	11.5	3.8
BDN18-3CB/A01	1.81	1.81	.355	.09	.072	.072	13x13	10.8	3.5
BDN18-6CB/A01			.605	.10	.128	.114	8x8	8.1	2.8
BDN19-3CB/A01	1.91	1.91	.355	.09	.069	.072	14x14	9.9	2.9
BDN21-3CB/A01	2.11	2.11	.355	.09	.064	.072	16x16	8.5	2.6

NOTES:

*Thermal resistance of adhesive tape is included.

**Thermal resistance values based on power density of 3 watts/in.²

***Part numbers listed for standard black anodized heat sinks with CTS adhesive tapes.

All dimensions are in inches.

FORGED HEAT SINKS WITH PLATE FINS

DESIGN FEATURES

- Precision forging technology for high power applications
- Designed for BGA and other surface mount packages
- Various mounting methods available
- Select from multiple fin heights

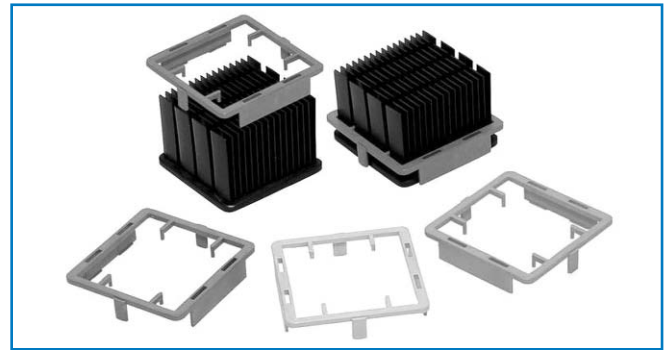
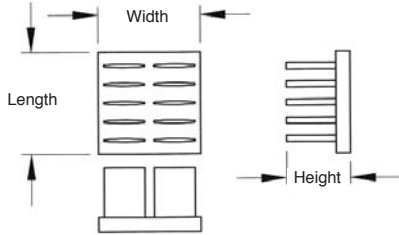

PRODUCT BENEFITS

- No special tools needed for assembly
- No additional holes required on the PCB
- Special clip easily snaps on and self-aligns

SERIES APF LOW-PROFILE FORGED HEAT SINKS (ADHESIVE ATTACH ONLY)

Part Number	Fin Matrix (Rows x Columns)	Length x Width x Height (mm)	Thermal Resistance (°C/Watt @ 200 LFPM)	Pressure Drop (inches of water)
APF19-19-06CB	12 x 2	19 x 19 x 6.3	7.1	0.033
APF19-19-10CB	12 x 2	19 x 19 x 9.5	5.3	0.033
APF19-19-13CB	12 x 2	19 x 19 x 12.7	4.0	0.033
APF30-30-06CB	19 x 3	30 x 30 x 6.3	4.4	0.039
APF30-30-10CB	19 x 3	30 x 30 x 9.5	3.3	0.039
APF30-30-13CB	19 x 3	30 x 30 x 12.7	2.5	0.039
APF40-40-06CB	26 x 4	40 x 40 x 6.3	3.3	0.043
APF40-40-10CB	26 x 4	40 x 40 x 9.5	2.5	0.043
APF40-40-13CB	26 x 4	40 x 40 x 12.7	1.9	0.043

SERIES AER FORGED HEAT SINKS

Part Number	Fin Matrix (Rows x Columns)	Length x Width x Height (mm)	Thermal Resistance (°C/Watt @ 200 LFPM)	Pressure Drop (inches of water)
AER19-19-12CB	2 x 6	18.6 x 18.6 x 11.6	7.2	0.017
AER19-19-15CB	2 x 6	18.6 x 18.6 x 14.6	6.6	0.017
AER19-19-18CB	2 x 6	18.6 x 18.6 x 17.6	5.4	0.017
AER19-19-21CB	2 x 6	18.6 x 18.6 x 20.6	4.7	0.017
AER19-19-23CB	2 x 6	18.6 x 18.6 x 22.6	4.3	0.017
AER19-19-28CB	2 x 6	18.6 x 18.6 x 27.6	3.8	0.017
AER19-19-33CB	2 x 6	18.6 x 18.6 x 32.6	3.3	0.017
AER21-21-12CB	2 x 7	20.6 x 20.6 x 11.6	7.2	0.017
AER21-21-15CB	2 x 7	20.6 x 20.6 x 14.6	6.6	0.017
AER21-21-18CB	2 x 7	20.6 x 20.6 x 17.6	5.4	0.017
AER21-21-21CB	2 x 7	20.6 x 20.6 x 20.6	4.7	0.017
AER21-21-23CB	2 x 7	20.6 x 20.6 x 22.6	4.3	0.017
AER21-21-28CB	2 x 7	20.6 x 20.6 x 27.6	3.8	0.017
AER21-21-33CB	2 x 7	20.6 x 20.6 x 32.6	3.3	0.017
AER23-23-12CB	2 x 8	22.6 x 22.6 x 11.6	6.2	0.018
AER23-23-15CB	2 x 8	22.6 x 22.6 x 14.6	5.4	0.018
AER23-23-18CB	2 x 8	22.6 x 22.6 x 17.6	4.4	0.018
AER23-23-21CB	2 x 8	22.6 x 22.6 x 20.6	3.8	0.018
AER23-23-23CB	2 x 8	22.6 x 22.6 x 22.6	3.5	0.018
AER23-23-28CB	2 x 8	22.6 x 22.6 x 27.6	3.1	0.018
AER23-23-33CB	2 x 8	22.6 x 22.6 x 32.6	2.7	0.018
AER25-25-12CB	3 x 9	24.6 x 24.6 x 11.6	5.3	0.020
AER25-25-15CB	3 x 9	24.6 x 24.6 x 14.6	4.6	0.020
AER25-25-18CB	3 x 9	24.6 x 24.6 x 17.6	3.8	0.020
AER25-25-21CB	3 x 9	24.6 x 24.6 x 20.6	3.3	0.020
AER25-25-23CB	3 x 9	24.6 x 24.6 x 22.6	3.0	0.020
AER25-25-28CB	3 x 9	24.6 x 24.6 x 27.6	2.7	0.020
AER25-25-33CB	3 x 9	24.6 x 24.6 x 32.6	2.4	0.020

MATERIAL: 6063 Aluminum Alloy, Black Anodized

SERIES AER FORGED HEAT SINKS

Part Number	Fin Matrix (Rows x Columns)	Length x Width x Height (mm)	Thermal Resistance (°C/Watt @ 200 LFPM)	Pressure Drop (inches of water)
AER27-27-12CB	3 x 9	26.6 x 26.6 x 11.6	5.2	0.020
AER27-27-15CB	3 x 9	26.6 x 26.6 x 14.6	4.5	0.020
AER27-27-18CB	3 x 9	26.6 x 26.6 x 17.6	3.7	0.020
AER27-27-21CB	3 x 9	26.6 x 26.6 x 20.6	3.1	0.020
AER27-27-23CB	3 x 9	26.6 x 26.6 x 22.6	2.9	0.020
AER27-27-28CB	3 x 9	26.6 x 26.6 x 27.6	2.7	0.020
AER27-27-33CB	3 x 9	26.6 x 26.6 x 32.6	2.3	0.020
AER29-29-12CB	3 x 9	28.6 x 28.6 x 11.6	4.4	0.020
AER29-29-15CB	3 x 9	28.6 x 28.6 x 14.6	3.8	0.020
AER29-29-18CB	3 x 9	28.6 x 28.6 x 17.6	3.2	0.020
AER29-29-21CB	3 x 9	28.6 x 28.6 x 20.6	2.7	0.020
AER29-29-23CB	3 x 9	28.6 x 28.6 x 22.6	2.5	0.020
AER29-29-28CB	3 x 9	28.6 x 28.6 x 27.6	2.4	0.020
AER29-29-33CB	3 x 9	28.6 x 28.6 x 32.6	2.2	0.020
AER31-31-12CB	3 x 11	30.6 x 30.6 x 11.6	3.4	0.014
AER31-31-15CB	3 x 11	30.6 x 30.6 x 14.6	3.3	0.014
AER31-31-18CB	3 x 11	30.6 x 30.6 x 17.6	2.7	0.014
AER31-31-21CB	3 x 11	30.6 x 30.6 x 20.6	2.3	0.014
AER31-31-23CB	3 x 11	30.6 x 30.6 x 22.6	2.1	0.014
AER31-31-28CB	3 x 11	30.6 x 30.6 x 27.6	1.9	0.014
AER31-31-33CB	3 x 11	30.6 x 30.6 x 32.6	1.7	0.014
AER33-33-12CB	3 x 11	32.6 x 32.6 x 11.6	3.4	0.012
AER33-33-15CB	3 x 11	32.6 x 32.6 x 14.6	2.9	0.012
AER33-33-18CB	3 x 11	32.6 x 32.6 x 17.6	2.4	0.012
AER33-33-21CB	3 x 11	32.6 x 32.6 x 20.6	1.9	0.012
AER33-33-23CB	3 x 11	32.6 x 32.6 x 22.6	1.7	0.012
AER33-33-28CB	3 x 11	32.6 x 32.6 x 27.6	1.5	0.012
AER33-33-33CB	3 x 11	32.6 x 32.6 x 32.6	1.3	0.012
AER35-35-12CB	4 x 12	34.6 x 34.6 x 11.6	3.3	0.018
AER35-35-15CB	4 x 12	34.6 x 34.6 x 14.6	2.9	0.018
AER35-35-18CB	4 x 12	34.6 x 34.6 x 17.6	2.4	0.018
AER35-35-21CB	4 x 12	34.6 x 34.6 x 20.6	2.1	0.018
AER35-35-23CB	4 x 12	34.6 x 34.6 x 22.6	1.8	0.018
AER35-35-28CB	4 x 12	34.6 x 34.6 x 27.6	1.5	0.018
AER35-35-33CB	4 x 12	34.6 x 34.6 x 32.6	1.3	0.018
AER38-38-12CB	4 x 13	37.1 x 37.1 x 11.6	3.2	0.025
AER38-38-15CB	4 x 13	37.1 x 37.1 x 14.6	2.7	0.025
AER38-38-18CB	4 x 13	37.1 x 37.1 x 17.6	2.2	0.025
AER38-38-21CB	4 x 13	37.1 x 37.1 x 20.6	1.9	0.025
AER38-38-23CB	4 x 13	37.1 x 37.1 x 22.6	1.8	0.025
AER38-38-28CB	4 x 13	37.1 x 37.1 x 27.6	1.5	0.025
AER38-38-33CB	4 x 13	37.1 x 37.1 x 32.6	1.3	0.025
AER40-40-12CB	4 x 14	39.6 x 39.6 x 11.6	2.6	0.026
AER40-40-15CB	4 x 14	39.6 x 39.6 x 14.6	2.4	0.026
AER40-40-18CB	4 x 14	39.6 x 39.6 x 17.6	1.9	0.026
AER40-40-21CB	4 x 14	39.6 x 39.6 x 20.6	1.7	0.026
AER40-40-23CB	4 x 14	39.6 x 39.6 x 22.6	1.5	0.026
AER40-40-28CB	4 x 14	39.6 x 39.6 x 27.6	1.4	0.026
AER40-40-33CB	4 x 14	39.6 x 39.6 x 32.6	1.2	0.026
AER43-43-12CB	4 x 15	42.1 x 42.1 x 11.6	2.4	0.027
AER43-43-15CB	4 x 15	42.1 x 42.1 x 14.6	2.1	0.027
AER43-43-18CB	4 x 15	42.1 x 42.1 x 17.6	1.7	0.027
AER43-43-21CB	4 x 15	42.1 x 42.1 x 20.6	1.5	0.027
AER43-43-23CB	4 x 15	42.1 x 42.1 x 22.6	1.3	0.027
AER43-43-28CB	4 x 15	42.1 x 42.1 x 27.6	1.2	0.027
AER43-43-33CB	4 x 15	42.1 x 42.1 x 32.6	1.1	0.027
AER45-45-12CB	4 x 16	44.6 x 44.6 x 11.6	2.3	0.020
AER45-45-15CB	4 x 16	44.6 x 44.6 x 14.6	1.9	0.020
AER45-45-18CB	4 x 16	44.6 x 44.6 x 17.6	1.6	0.020
AER45-45-21CB	4 x 16	44.6 x 44.6 x 20.6	1.4	0.020
AER45-45-23CB	4 x 16	44.6 x 44.6 x 22.6	1.2	0.020
AER45-45-28CB	4 x 16	44.6 x 44.6 x 27.6	1.1	0.020
AER45-45-33CB	4 x 16	44.6 x 44.6 x 32.6	0.9	0.020

MATERIAL: 6063 Aluminum Alloy, Black Anodized

FORGED HEAT SINKS WITH PIN FINS

DESIGN FEATURES

- Precision forging technology for high power applications
- Omnidirectional pins
- Designed for BGA and other surface mount packages
- Various mounting methods available
- Select from multiple fin heights

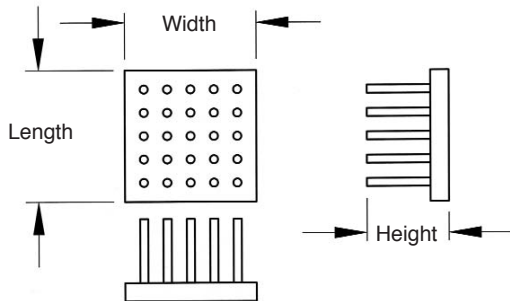
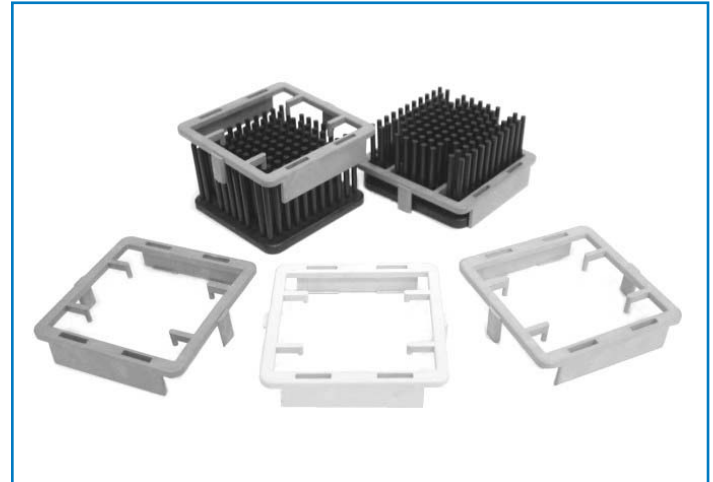

PRODUCT BENEFITS

- No special tools needed for assembly
- No additional holes required on the PCB
- Special clip easily snaps on and self-aligns

SERIES APR FORGED ALUMINUM HEAT SINKS WITH PIN FINS

Part Number	Fin Matrix (Rows x Columns)	Length x Width x Height (mm)	Thermal Resistance (°C/Watt @ 200 LFPM)	Pressure Drop (inches of water)
APR19-19-12CB	5 x 5	18.6 x 18.6 x 11.6	7.7	0.013
APR19-19-15CB	5 x 5	18.6 x 18.6 x 14.6	7.4	0.013
APR19-19-20CB	5 x 5	18.6 x 18.6 x 19.6	4.9	0.013
APR19-19-25CB	5 x 5	18.6 x 18.6 x 24.6	4.6	0.013
APR27-27-12CB	8 x 8	26.6 x 26.6 x 11.6	5.3	0.015
APR27-27-15CB	8 x 8	26.6 x 26.6 x 14.6	4.4	0.015
APR27-27-20CB	8 x 8	26.6 x 26.6 x 19.6	3.1	0.015
APR27-27-25CB	8 x 8	26.6 x 26.6 x 24.6	2.8	0.015
APR29-29-12CB	8 x 8	28.6 x 28.6 x 11.6	3.9	0.018
APR29-29-15CB	8 x 8	28.6 x 28.6 x 14.6	3.7	0.018
APR29-29-20CB	8 x 8	28.6 x 28.6 x 19.6	2.6	0.018
APR29-29-25CB	8 x 8	28.6 x 28.6 x 24.6	2.5	0.018
APR33-33-12CB	9 x 9	32.6 x 32.6 x 11.6	3.8	0.020
APR33-33-15CB	9 x 9	32.6 x 32.6 x 14.6	3.2	0.020
APR33-33-20CB	9 x 9	32.6 x 32.6 x 19.6	2.4	0.020
APR33-33-25CB	9 x 9	32.6 x 32.6 x 24.6	1.9	0.020
APR35-35-12CB	10 x 10	34.7 x 34.7 x 11.6	3.5	0.022
APR35-35-15CB	10 x 10	34.7 x 34.7 x 14.6	2.9	0.022
APR35-35-20CB	10 x 10	34.7 x 34.7 x 19.6	2.0	0.022
APR35-35-25CB	10 x 10	34.7 x 34.7 x 24.6	1.8	0.022
APR38-38-12CB	11 x 11	37.1 x 37.1 x 11.6	3.3	0.025
APR38-38-15CB	11 x 11	37.1 x 37.1 x 14.6	2.7	0.025
APR38-38-20CB	11 x 11	37.1 x 37.1 x 19.6	1.9	0.025
APR38-38-25CB	11 x 11	37.1 x 37.1 x 24.6	1.5	0.025
APR40-40-12CB	11 x 11	39.6 x 39.6 x 11.6	2.8	0.027
APR40-40-15CB	11 x 11	39.6 x 39.6 x 14.6	2.3	0.027
APR40-40-20CB	11 x 11	39.6 x 39.6 x 19.6	1.6	0.027
APR40-40-25CB	11 x 11	39.6 x 39.6 x 24.6	1.4	0.027
APR43-43-12CB	12 x 12	42.1 x 42.1 x 11.6	2.5	0.029
APR43-43-15CB	12 x 12	42.1 x 42.1 x 14.6	2.0	0.029
APR43-43-20CB	12 x 12	42.1 x 42.1 x 19.6	1.5	0.029
APR43-43-25CB	12 x 12	42.1 x 42.1 x 24.6	1.2	0.029

MATERIAL: 6063 Aluminum Alloy, Black Anodized

CLIP STYLES

MATERIAL: Nylon Plastic per UL94-V0



Component Size Length x Width (mm)	0.9mm +/- 0.3mm Short Height Color: Orange	1.7mm +/- 0.3mm Medium Height Color: Blue	3.3mm +/- 0.3mm Tall Height Color: Yellow	Clip Size Length x Width x Height (mm)
	Part Number			
19 x 19	C1919S	C1919M	C1919T	21.2 x 21.2 x 9.1
21 x 21	C2121S	C2121M	C2121T	23.2 x 23.7 x 9.1
23 x 23	C2323S	C2323M	C2323T	25.2 x 25.7 x 9.1
25 x 25	C2525S	C2525M	C2525T	27.2 x 27.7 x 9.1
27 x 27	C2727S	C2727M	C2727T	29.2 x 29.7 x 9.1
29 x 29	C2929S	C2929M	C2929T	31.2 x 31.2 x 9.1
31 x 31	C3131S	C3131M	C3131T	33.2 x 33.7 x 9.1
33 x 33	C3333S	C3333M	C3333T	35.2 x 35.2 x 9.1
35 x 35	C3535S	C3535M	C3535T	37.2 x 37.7 x 9.1
37.5 x 37.5	C3838S	C3838M	C3838T	39.7 x 40.2 x 9.1
40 x 40	C4040S	C4040M	C4040T	42.2 x 42.7 x 9.1
42.5 x 42.5	C4343S	C4343M	C4343T	44.7 x 45.1 x 9.1
45 x 45	C4545S	C4545M	C4545T	47.2 x 47.7 x 9.1

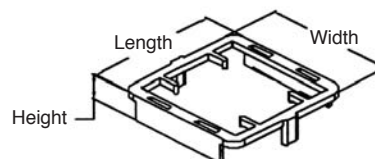

TAPE STYLES

Thermal Tape	Supplier	Thickness (mm)	Thermal Impedance (°C-in. ² /W)	Dielectric Strength (V/mil)	Description
A01	CTS	0.13	0.82	4,000	Double-sided acrylic adhesive on a Kapton® MT carrier
T410	Chomerics	0.18	1.10	N/A	Double-sided acrylic adhesive loaded with aluminum oxide on an aluminum foil carrier
T411	Chomerics	0.28	1.00	N/A	Double-sided silicone adhesive with expanded aluminum mesh carrier
T412	Chomerics	0.23	0.25	N/A	Doubled-sided acrylic adhesive loaded with titanium diboride on an expanded aluminum carrier
8815	3M	0.38	1.20	668	Double-sided acrylic adhesive loaded with ceramic particles

ORDERING INFORMATION

AER - 19-19-12 - CB - /A01

Part Number Series ————

Dimensions in mm (LxWxH) ————

Mounting Options (Clip or Adhesive) →

Commercial Black Anodize

CLIP	ADHESIVE
Short "S"	Double-sided Kapton® "/A01"
Medium "M"	Chomerics Thermattach®
Tall "T"	"/T410, T411, or T412"
	3M™ "/8815"

STANDARD ZIF CIRCUIT BOARD RETAINERS



GENERAL DESCRIPTION

The ZIF retainer is a totally self-contained, precision assembly that provides a highly effective thermal interface between the circuit board and coldwall. Board lengths between 1-1/2" and 12" can be accommodated.

A ZIF retainer consists of:

- (1) an aluminum housing
- (2) a rod/cam assembly constructed from an aluminum or stainless steel double flat rod extrusion. The ZIF rod assembly is driven by one of three options: pin, hex-head or screwdriver slot
- (3) a beryllium copper spring

ZIF retainers are mounted to any flat metal surface (coldwall). The standard configuration is attached with 4-40 hardware. However, the retainer housing can be supplied with tapped holes for M3x.5 metric hardware, or left undrilled with only index pins for vacuum brazing, dip brazing or epoxy bonding.

ZIF OPERATION

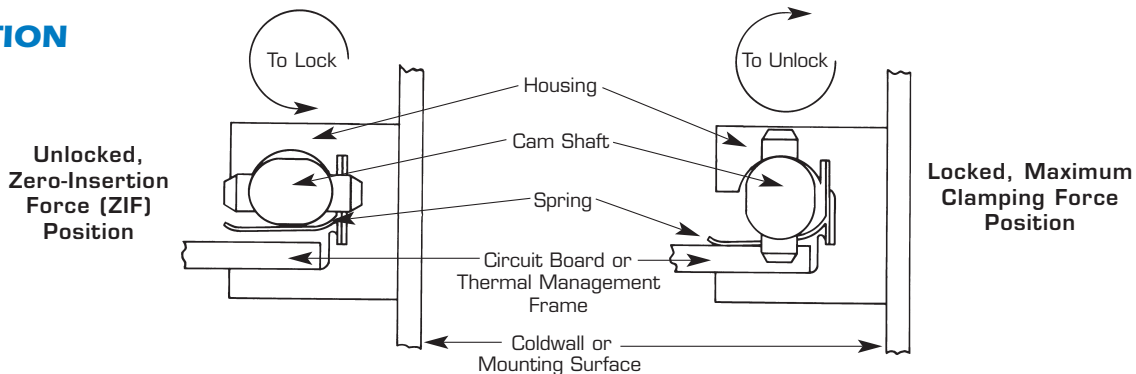

Improving the thermal conductivity of circuit board retainers enhances system performance by increasing the reliability of electronic components and circuit modules. Extensive testing of ZIF retainers in the CTS Engineering Test Laboratory demonstrates that they have the best thermal performance of any circuit board retainer available.

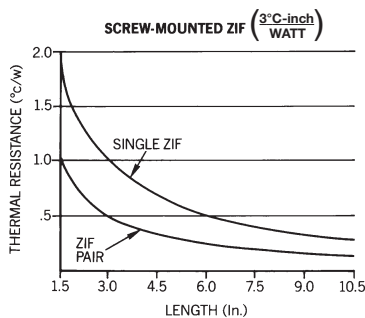

Clamping pressure is not only essential to heat transfer, but also a critical requirement for retention of PCBs under severe shock and vibration. ZIF retainers have been subjected to the most extreme test conditions specified in MIL-STD-810C. Nominal retention force for a circuit board held captive by a pair of ZIF retainers (I/O connector excluded) is shown in the graph.

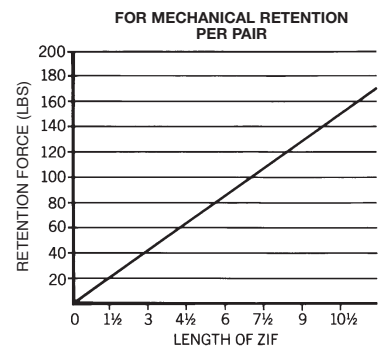

DESIGN FEATURES

- QUICK LOCKING ACTION
- UNIFORM HEAT TRANSFER
- COMPLETE INTERCHANGEABILITY
- VISUAL INDICATION OF LOCK/UNLOCK

TECHNICAL ASSISTANCE-CUSTOM DESIGNS

Our engineering staff has extensive experience in the packaging of ZIF retainers. Modification of standard housings, cams and spring configurations for special design applications is frequently possible. We welcome the opportunity of providing you with the assistance needed to solve all of your thermal management problems.

SPECIFICATIONS

The ZIF cam detent design gives added assurance that a PCB will remain securely locked in position even under extreme vibration and shock levels. Detent action occurs during the final 15 degrees of cam rotation and virtually eliminates any possibility of the cam unlocking under environmental stress.

ORDERING INFORMATION - STANDARD ZIF

Z A S 1 1 1 - 062 - 15 R* - B B U

ZIF Designation
Assembly Option
 A=Assembled K=Kit
Mounting Method
 B=Brazed
 S=Screws 4-40
 M=Metric Screws (M3x0.5)
Housing Series
 1=Without Pins
 2=With .062x.040
 Extended Aluminum Index Pins
Rod Assembly
 1=Pin Drive, Aluminum Rod (6" Max.)
 2=Pin Drive, Steel Rod
 3=Slot Drive, Steel Rod (4.5" Max.)
 4=1/4 Hex Drive, Aluminum Rod
 7=3/16 Hex Drive, Steel Rod
 ①S=3/16 Hex Drive, Steel Rod
 ①Z=1/8" Socket Head Cap, Steel Rod
Spring Series
 1=Current Design
Board Thickness (±.005 Max.)
 .031" .050" .062" .084" .093" .125"

Spring Plating
 U=Unplated
 B=Black Cadmium
 N=Nickel
Rod Plating
 B=Black Anod. Aluminum Rods
 P=Passivated, Steel Rods
Housing Plating
 B=Black Anodize
 U=Unplated
 R=Chem. Film
 R=Right Hand Part
 L=Left Hand Part
 Assembly Length in .5" Increments x 2
 Ex: 7.5"=15

*All assembled ZIFs must have a left or right designation.
 Any kit with a 1/4 inch hexhead drive must have a left or right designation.

① Visual identification slot painted yellow.

ROD STYLES

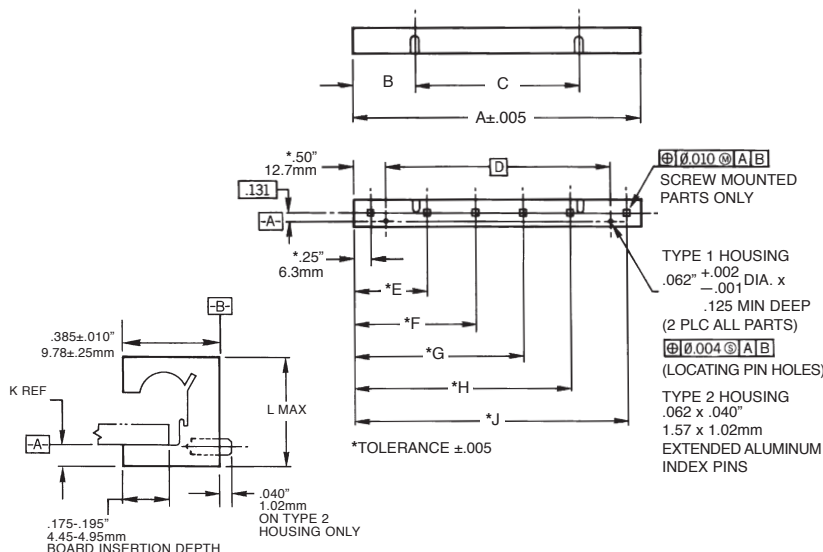
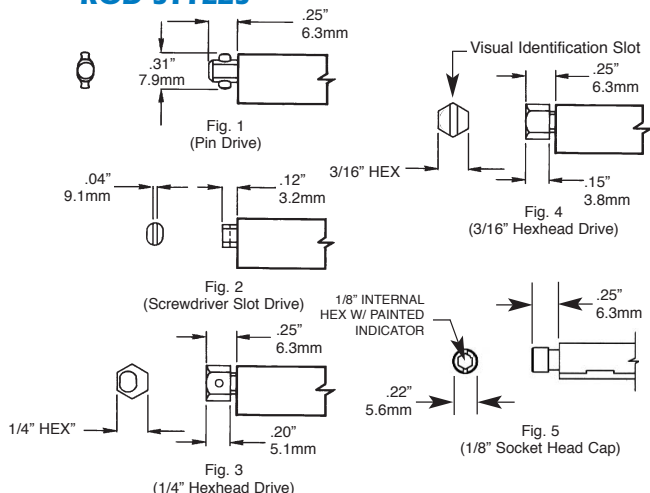

ROD TYPE			
DESIG.	FIG. NO.	MATERIAL	MAX. SPRING LENGTH
ZRA1	1	aluminum	6 inches
ZRA2	1	steel	10.5 inches
ZRA3	2	steel	4.5 inches
ZRA4	3	aluminum	10.5 inches
ZRA7	4	steel	10.5 inches
①ZRAS	4	steel	10.5 inches

ZIF HOUSING DIMENSIONS											
LENGTH DESIGNATION	SPRING LENGTH	A ±.005	B	C	D	4-40 MOUNTING HOLES					NO. OF MNTG. HOLES
						E	F	G	H	J	
03	1.5	1.50	.75	—	.50	1.25	—	—	—	—	2
04	1.5	2.00	1.00	—	1.00	1.75	—	—	—	—	2
05	1.5	2.50	1.25	—	1.50	2.25	—	—	—	—	2
06	3	3.00	.75	1.5	2.00	1.50	2.75	—	—	—	3
07	3	3.50	1.00	1.5	2.50	1.75	3.25	—	—	—	3
08	3	4.00	1.25	1.5	3.00	2.00	3.75	—	—	—	3
09	4.5	4.50	.75	3.0	3.50	2.25	4.25	—	—	—	3
10	4.5	5.00	1.00	3.0	4.00	1.75	3.25	4.75	—	—	4
11	4.5	5.50	1.25	3.0	4.50	2.00	3.50	5.25	—	—	4
12	6	6.00	.75	4.5	5.00	2.00	4.00	5.75	—	—	4
13	6	6.50	1.00	4.5	5.50	2.25	4.25	6.25	—	—	4
14	6	7.00	1.25	4.5	6.00	2.50	4.50	6.75	—	—	4
15	7.5	7.50	2.25	3.0	6.50	2.00	3.75	5.50	7.25	—	5
16	7.5	8.00	2.50	3.0	7.00	2.00	4.00	6.00	7.25	—	5
17	7.5	8.50	2.75	3.0	7.50	2.25	4.25	6.25	8.25	—	5
18	9	9.00	3.75	1.5	8.00	2.50	4.50	6.50	8.75	—	5
19	9	9.50	4.00	1.5	8.50	2.00	3.75	5.75	7.50	9.25	6
20	9	10.00	4.25	1.5	9.00	2.00	4.00	6.00	8.00	9.75	6
21	10.5	10.50	5.25	—	9.50	2.25	4.25	6.25	8.25	10.25	6

ZIF circuit board retainers are available in several standard configurations. When ordering standard ZIF assemblies, kits or individual components, please refer to the ZIF identification number guide shown above. Custom ZIF retainers will be assigned special part number identification.

BOARD THICK	K REF	L MAX
.031"	.094"	.400"
.79mm	2.39mm	10.16mm
.050"	.075"	.400"
1.27mm	1.90mm	10.16mm
.062"	.063"	.400"
1.57mm	1.60mm	10.16mm
.084"	.063"	.422"
2.13mm	1.60mm	10.72mm
.093"	.079"	.447"
2.36mm	2.01mm	11.34mm
.125"	.082"	.478"
3.17mm	2.08mm	12.11mm

All dimensions are in inches unless otherwise noted.

ZIF III CIRCUIT BOARD RETAINERS

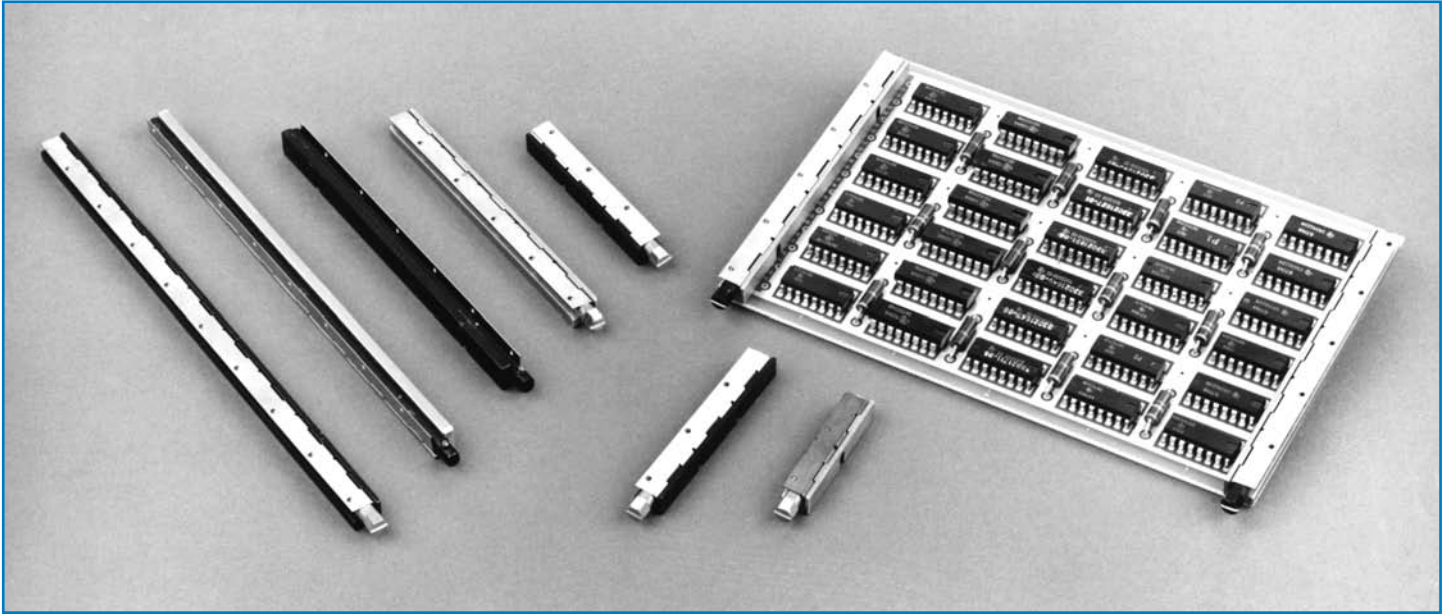

GENERAL DESCRIPTION

ZIF III retainers are the latest in the state-of-the-art PC board mountable retainers. Unlike other designs on the market, CTS's ZIF III features a quick, quarter-turn locking mechanism that provides for a positive and fast assembly. Its unique locking design produces a uniform pressure distribution along the PCB edge for the absolute best heat transfer and resistance to extreme shock and vibration. It will not warp your circuit boards unlike some others available in the market. If you have high density PC board mounting applications for military, space, medical, industrial controls, computers and communications, you need ZIF III Circuit Board Retainers.

DESIGN FEATURES

- **PC BOARD MOUNTABLE**
- **POSITIVE 1/4 TURN LOCKING**
- **FIELD MAINTAINABLE**
- **QUICK AND EASY INSTALLATION**
- **SUPERIOR MECHANICAL RETENTION**
- **THERMALLY EFFICIENT, 0.9 °C-INCH/WATT**

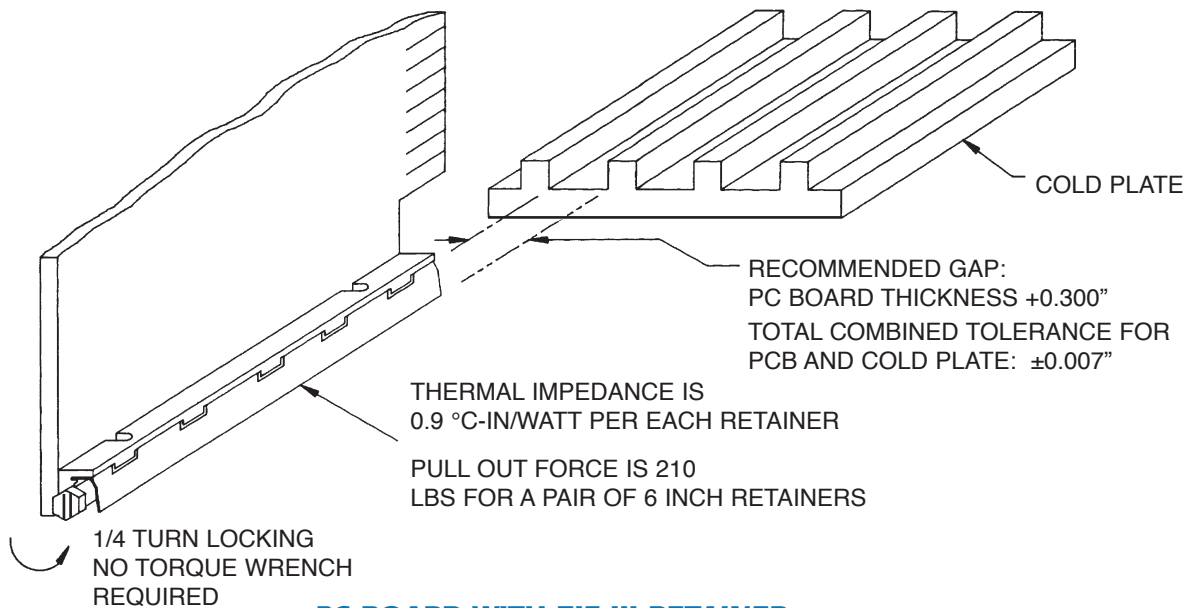

ORDERING INFORMATION - ZIF III

Z 3 A 3 7 S B - 3 - B N L

ZIF III DESIGNATION

TOP ASSEMBLY OPTION

A=Assembled B=Kit

LENGTH OF HOUSING ASSEMBLY

- 15=1.50 Inch
- 22=2.25 Inch
- 30=3.00 Inch
- 37=3.75 Inch
- 45=4.50 Inch
- 52=5.25 Inch
- 60=6.00 Inch
- 67=6.75 Inch
- 75=7.50 Inch

Consult factory for custom or longer lengths.

MOUNTING TYPE

- S=Screw Mounting (2-56)
- B=No Holes
- I=2-56 Helical Insert (Locking)
- M=Screw Mounting (M3x.05)

HOUSING FINISH

- B=Black Anodize
- U=Unplated
- R=Chemical Film

R=Right Hand Part
L=Left Hand Part

SPRING FINISH

- U=Unplated
- B=Black Cadmium
- N=Nickel

SPRING MATERIAL

B=Be Cu

ROD TYPE

- 1=Pin Drive, Aluminum Rod 4.5" Max.
- 2=Pin Drive, Stainless Steel
- 3=Slot Drive, Stainless Steel 3.75" Max.
- 7=3/16 Hex Drive, Stainless Steel
- S=Type 7 With Painted Indicator
- Z=1/8" Socket Head Cap, Stainless Steel Rod w/ Painted Indicator

SPECIFICATIONS

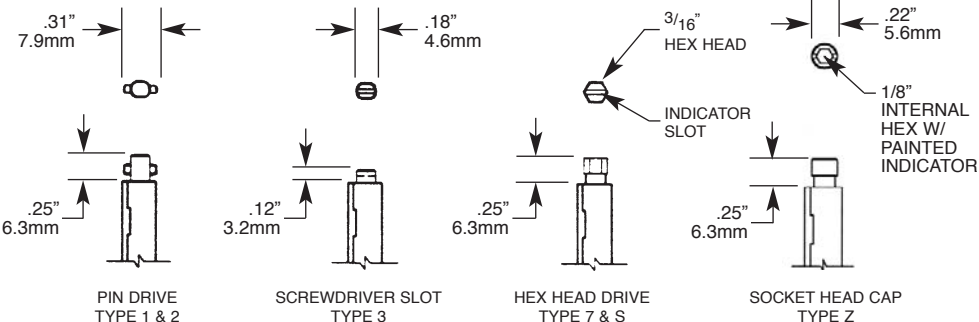
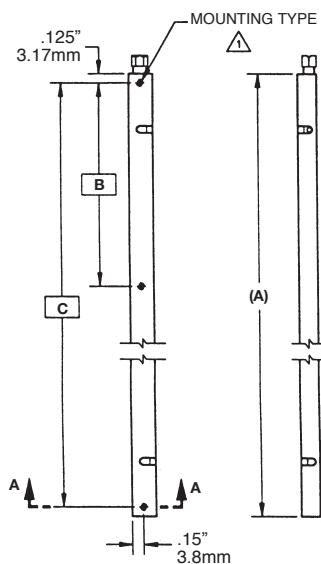

ROD STYLES

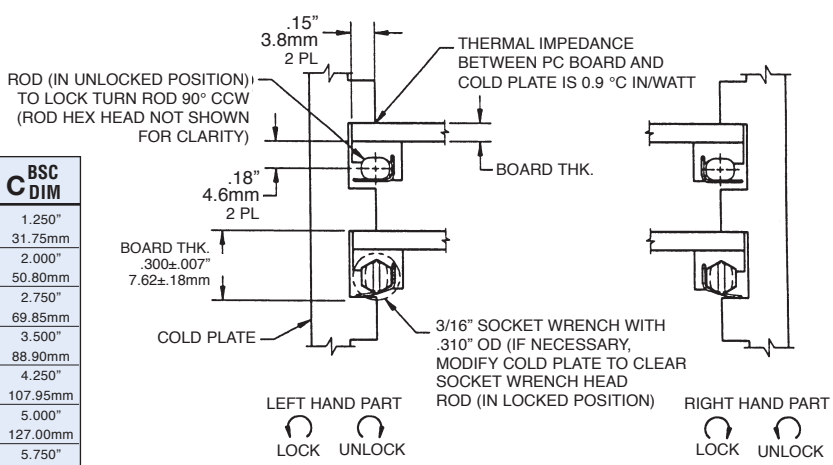

ADIM	BSC DIM	C DIM
1.500"	—	1.250"
38.10mm	—	31.75mm
2.250"	—	2.000"
57.15mm	—	50.80mm
3.000"	—	2.750"
76.20mm	—	69.85mm
3.750"	—	3.500"
95.25mm	—	88.90mm
4.500"	—	4.250"
114.30mm	—	107.95mm
5.250"	—	5.000"
133.35mm	—	127.00mm
6.000"	2.875"	5.750"
152.40mm	7.03mm	146.05mm
6.750"	3.250"	6.500"
171.45mm	82.55mm	165.10mm
7.500"	3.625"	7.250"
190.50mm	92.08mm	184.15mm

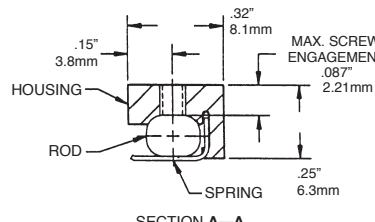

TOTAL WEIGHT PER ASSEMBLY:
ALUMINUM ROD 3.42 GRAM/IN.
STAINLESS STEEL 5.23 GRAM/IN.

All dimensions are in inches unless otherwise noted.

Dimensions are for reference use only. Contact CTS for dimensions with tolerances or standard part drawings.

ZIF PRIME CIRCUIT BOARD RETAINERS

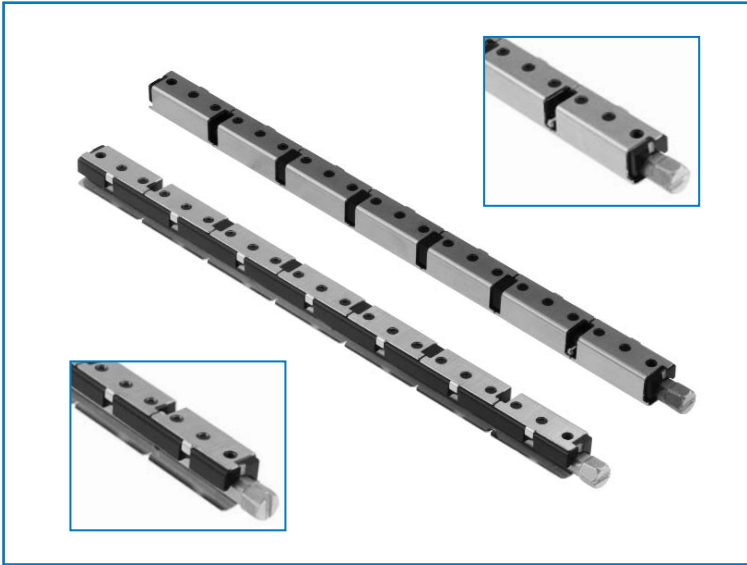

DESIGN FEATURES

- PC BOARD MOUNTABLE
- POSITIVE 1/4 TURN LOCKING
- QUICK INSTALLATION
- SUPERIOR MECHANICAL RETENTION
- THERMALLY EFFICIENT, 0.9° C-INCH/WATT

GENERAL DESCRIPTION

The ZIF Prime is the latest in state-of-the-art rugged retainers released by CTS Electronic Components. It offers the most common finish and actuation styles and maintains the superior thermal and mechanical features of the ZIF III. New additional features include lower locking/unlocking torque requirements and enhanced visual indication of locked/unlocked status.

The ZIF Prime is a totally self-contained precision assembly that provides a highly effective thermal and mechanical interface between the circuit board and coldwall. The ZIF Prime retainer is mounted to a heat frame or directly to the PC board and provides exceptional thermal performance while allowing the rapid exchange of electronic circuitry to minimize equipment downtime.

Primary characteristics of the ZIF family of retainers include quick and easy installation with a 1/4 turn lock and unlock, uniform contact area to enable uniform board pressure and heat transfer, superior thermal performance and capability to withstand rugged environments.

PRODUCT BENEFITS

- Standard parts consist of:
 - Aluminum housing with black anodize finish
 - Stainless steel rod with 3/16 in. external hex head, passivated
 - Beryllium copper spring, electroless nickel-plated
 - 2-56 screw mounting
- Thermal impedance of 0.9° C-in/W (equivalent to ZIF III)
- Direct drop-in for ZIF III parts in terms of performance and mounting pattern
- Same 1/4 turn locking procedure as Standard ZIF and ZIF III products
- Enhanced visual indication method for determining locked/unlocked part status
- Recommended slot width of .300 in. (7.62mm) + PC board thickness; tolerance ±0.005 in. (0.13mm)
- Capable of operating in rugged environments as per MIL-STD-810

MECHANICAL AND THERMAL CHARACTERISTICS			
	3.75 in. (95.25mm)	5.25 in. (133.35mm)	6.75 in. (171.45mm)
Clamping Force lb. (N)	112 (500)	157 (700)	202 (900)
Retention Force lb. (N)	60 (265)	83 (370)	107 (480)
Thermal Resistance °C/W	0.32	0.23	0.18

This table indicates the mechanical and thermal characteristics of the ZIF Prime based on different retainer lengths. The values shown are for a pair at nominal dimensions and can be used as a baseline for design purposes. ZIF Prime retainers should be tested in final customer configurations as mechanical interfaces can impact retainer performance.

ZIF PRIME SPECIFICATIONS

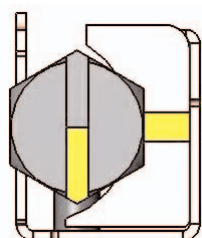

UNLOCKED

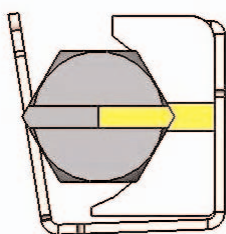

LOCKED

DIMENSIONAL SPECIFICATIONS			
Part Number	"A" DIM	"B" DIM	"C" DIM
ZAP-22-R or ZAP-22-L	2.25 in (57.15mm)	—	2.00 in (50.80mm)
ZAP-30-R or ZAP-30-L	3.00 in (76.20mm)	—	2.75 in (69.85mm)
ZAP-37-R or ZAP-37-L	3.75 in (95.25mm)	—	3.50 in (88.90mm)
ZAP-45-R or ZAP-45-L	4.50 in (114.30mm)	—	4.25 in (107.95mm)
ZAP-52-R or ZAP-52-L	5.25 in (133.35mm)	—	5.00 in (127.00mm)
ZAP-60-R or ZAP-60-L	6.00 in (152.40mm)	2.875 in (73.03mm)	5.75 in (146.05mm)
ZAP-67-R or ZAP-67-L	6.75 in (171.45mm)	3.250 in (82.55mm)	6.50 in (165.10mm)
ZAP-75-R or ZAP-75-L	7.50 in (190.50mm)	3.625 in (92.08mm)	7.25 in (184.15mm)

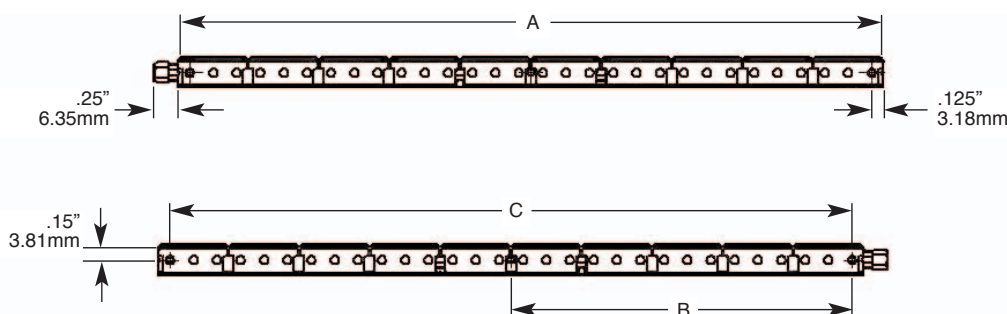

All dimensions are in inches unless otherwise noted.

The ZIF Prime consists of three precision manufactured parts — the housing, spring, and rod. The following military and federal specifications are followed in the manufacture of all ZIF rugged retainers and their components.

FEDERAL

QQ-A-200/9, Aluminum Alloy 6063, Bar, Rod, Shapes, Tube and Wire, Extruded

QQ-S-763, Steel Bars, Wire, Shapes, Forgings, Corrosion Resistant

QQ-C-533, Copper Beryllium Alloy Strip

QQ-P-35, Passivation of Stainless Steel

THE MILITARY

MIL-A-8625, Anodic Coatings for Aluminum and Aluminum Alloys

MIL-C-26074, Coatings, Electroless Nickel

MIL-STD-810, Test Method Standard for Environmental Engineering Considerations and Laboratory Tests

MIL-P-24441/9, Paint, Epoxy-Polyamide, Primer, Yellow, Formula 158, Type 1

MIL-C-5541, Chemical Conversion Coatings on Aluminum and Aluminum Alloys

MIL-I-45208, Inspection System Requirements

Dimensions are for reference use only. Contact CTS for dimensions with tolerances or standard part drawings.

THERMAL LINKS

GENERAL DESCRIPTION

CTS' thermal links provide an effective retainer and efficient thermal path between semiconductor and heat sinks or chassis. CTS' unique design gives

superior retention and thermal conductivity due to their 6 to 8-segment fingers versus the 2 or 3-segment fingers available from other manufacturers.

THERMAL LINKS FOR TO-5, TO-8 AND TO-18 TRANSISTORS

Thermal Link Retainers Without BeO Insulators

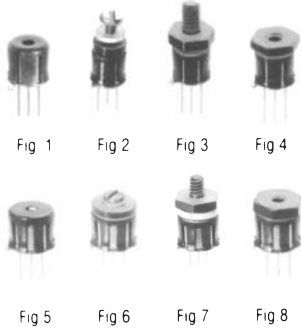
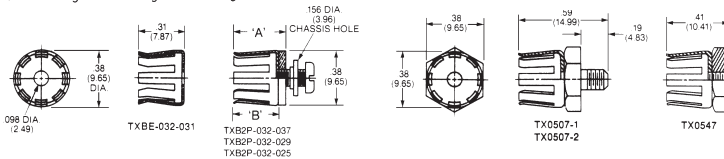

Fig. #	Semiconductor Case Type	Part Number		Mounting Method
		Black Cadmium Finish	Dull Nickel Finish	
1	TO-18	TXBE-019-021B	TXBE-019-021ND	Rivet/Solder
2	TO-18	TXB2P-019-028B	TXB2P-019-028ND	2-56 Screw
3	TO-18	TX1807B	TX1807ND	4-40 Stud
3	TO-18	TX1807-1B	TX1807-1ND	6-32 Stud
4	TO-18	TX1847B	TX1847ND	2-56 Hex Nut
5	TO-5	TXBE-032-031B	TXBE-032-031ND	Rivet/Solder
6	TO-5	TXB2P-032-037B	TXB2P-032-037ND	4-40 Screw
7	TO-5	TX0507-1B	TX0507-1ND	6-32 Stud
7	TO-5	TX0507-2B	TX0507-2ND	10-32 Stud
8	TO-5	TX0547B	TX0547ND	14-40 Hex Nut



Dimensions are for reference use only. Contact CTS for dimensions with tolerances or standard part drawings.

Thermal Link Retainers With BeO Insulators

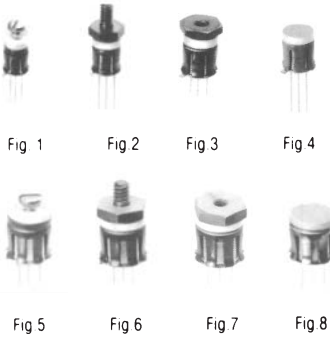
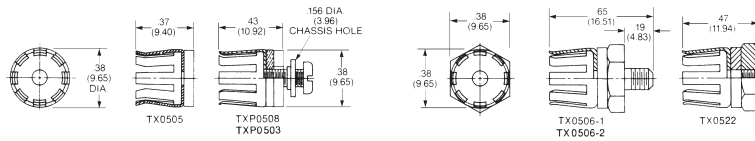

Fig. #	Semiconductor Case Type	Part Number		Mounting Method
		Black Cadmium Finish	Dull Nickel Finish	
1	TO-18	TXP1803B	TXP1803ND	2-56 Screw
1	TO-18**	TXP1808B	TXP1808ND	2-56 Screw
2	TO-18	TX1806B	TX1806ND	4-40 Stud
2	TO-18	TX1806-1B	TX1806-1ND	6-32 Stud
3	TO-18	TX1822B	TX1822ND	2-56 Hex Nut
4	TO-18	—	TX1805-ND	Solder
5	TO-5	TXP0503B	TXP0503ND	4-40 Screw
5	TO-5**	TXP0508B	TXP0508ND	4-40 Screw
6	TO-5	TX0506-1B	TX0506-1ND	6-32 Stud
6	TO-5	TX0506-2B	TX0506-2ND	10-32 Stud
7	TO-5	TX0522B	TX0522ND	4-40 Hex Nut
8	TO-5	—	TX0505-ND	Solder



Dimensions are for reference use only. Contact CTS for dimensions with tolerances or standard part drawings.

**BeO and thermal link are brazed together.

THERMAL LINKS FOR TO-8s

Thermal Link Retainers Without BeO Insulators

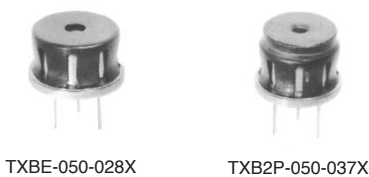

Part Number		Mounting Method	Max. Weight (Grams)	Case Diameter
Black Cadmium Finish	Dull Nickel Finish			
TXBE-045-028B	TXBE-045-028ND	Solder, Epoxy, Rivet	1.5	0.455
TXB2P-045-037B	TXB2P-045-037ND	4-40 Screw	4.5	0.455
TXBE-050-028B	TXBE-050-028ND	Solder, Epoxy, Rivet	1.5	0.500
TXB2P-050-037B	TXB2P-050-037ND	4-40 Screw	4.5	0.500
TXBE-055-028B	TXBE-055-028ND	Solder, Epoxy, Rivet	1.5	0.550
TXB2P-055-037B	TXB2P-055-037ND	4-40 Screw	4.5	0.550

Screw and shouldered nylon washer for .060 chassis included; If mounting hardware not desired, deleted "P" from part number.

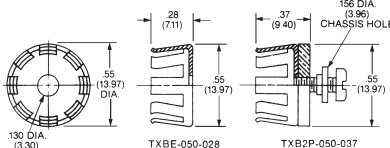

Dimensions are for reference use only. Contact CTS for dimensions with tolerances or standard part drawings.

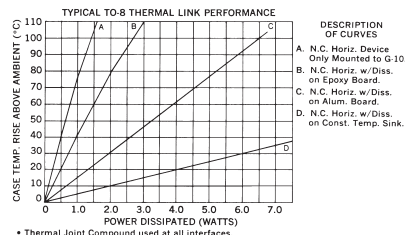

ADDITIONAL EXTRUDED PRODUCTS FOR TO-126, TO-202, TO-218 AND TO-220 TRANSISTORS

7-338 & 7-339-1, -2, -3, -4

Tin-plated steel roll pins for solder mount.

Material ... 6063-T5 aluminum
Finish ... Black Anodize

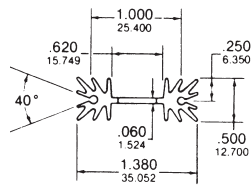
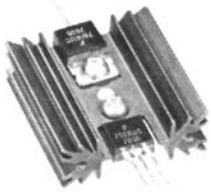

7-338

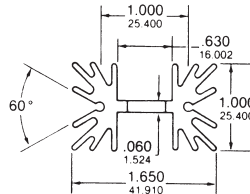

7-339

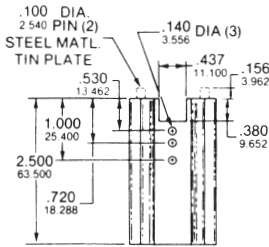
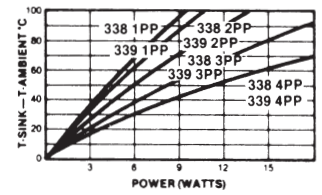

4PP

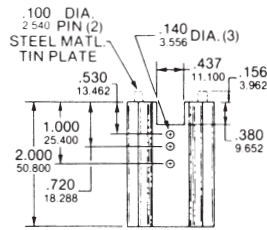

3PP

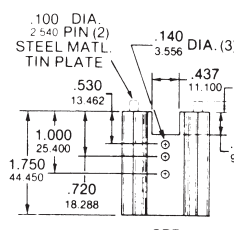

2PP

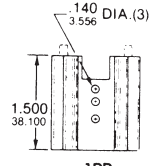

1PP

7-340-1, -2, -3, -4

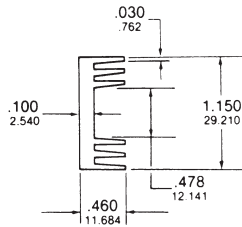
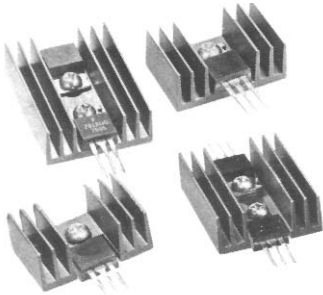

Material ... 6063-T5 Aluminum
Finish ... Black Anodize

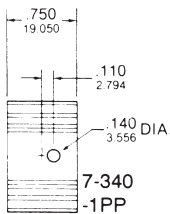
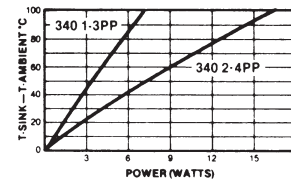

7-340
-1PP

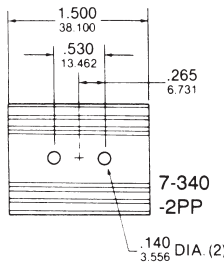

7-340
-2PP

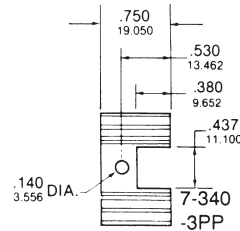

7-340
-3PP

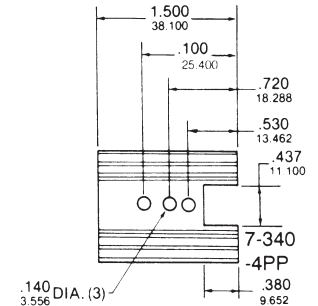

7-340
-4PP

7-345-1, -2, -3, -4

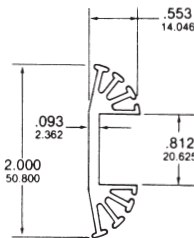

Material ... 6063-T5 Aluminum
Finish ... Black Anodize

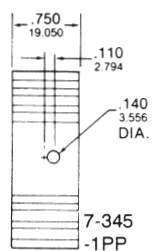
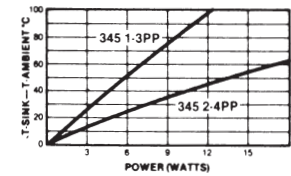

7-345
-1PP

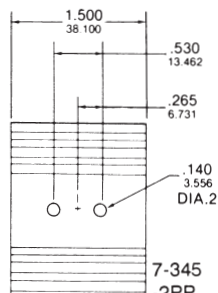

7-345
-2PP

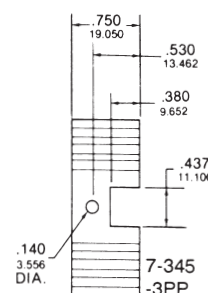

7-345
-3PP

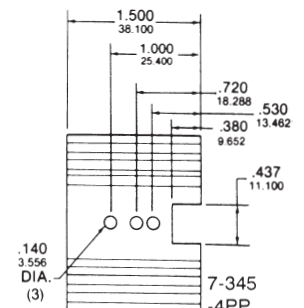

7-345
-4PP



LA-A Series

Semiconductor Case Type	*Ø °C/W	Part Number		"A" Dim.
		Commercial Black	Military Black	
TO-66	14.4	—	LAD66A4	1.00
TO-126/127/220	17.0	LAE66A3CB	—	.75
TO-126/127/220	14.7	LAE66A4CB	—	1.00

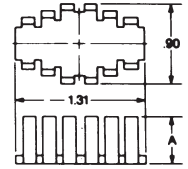

LA-B Series

Semiconductor Case Type	*Ø °C/W	Part Number		"A" Dim.
		Commercial Black	Military Black	
TO-3	10.7	—	LAIC3B3B	1.00
TO-3	10.3	—	LAT03B4B	1.00
TO-3	9.3	LAT03B5CB	—	1.25

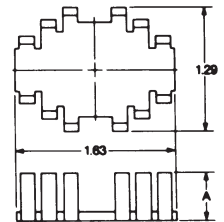

*Natural convection, case-ambient mounted on G10 board



UP and UP1 Series

Semiconductor Case Type	*Ø °C/W	Part Number		"A" Dim.
		Commercial Black	Military Black	
TO-3	10.4	UP1-TO3-CB	—	.50
TO-3	7.1	UP-TO3-CB	UP-TO3-B	1.00

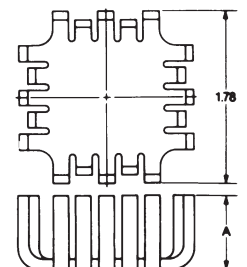

BOARD-MOUNTED HEAT SINKS

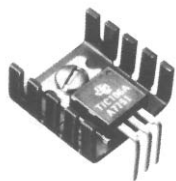

PC Series

Semiconductor Case Type	*Ø °C/W	Part Number		"A" Dim.
		Commercial Black		
TO-126/127/220	27.3	PC1-1CB		.38

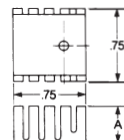

PA Series

Semiconductor Case Type	*Ø °C/W	Part Number		"A" Dim.
		Unplated	Commercial Black	
TO-126/127/220	28.8	PA1-1U	PA1-1CB	.50

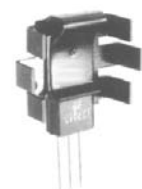
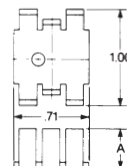

PSC2 Series

Semiconductor Case Type	*Ø °C/W	Part Number	
		Unplated	Commercial Black
TO-220 (Anti-Rotation Tabs)	36.7	PSC2T2U	PSC2T2CB

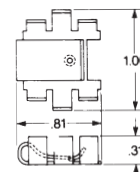

VERTICALLY MOUNTED HEAT SINKS WITH BOARD-MOUNTED TABS

Vertical Tab Mounted Heat Sinks



Fig. 1

Semiconductor Case Type	*Ø °C/W	Part Number	
		Commercial Black	
TO-126/127/220	20.0	PB1-36CB	

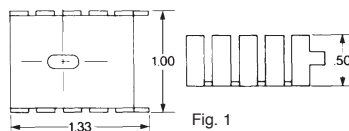
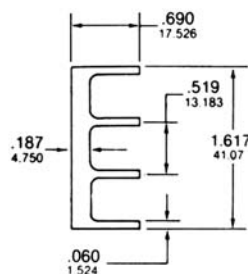

Fig. 1

*Natural convection, case-ambient mounted on G10 board

7-342-1, -2, -3, -4



Material 6063-T5 Aluminum
Finish Black Anodize

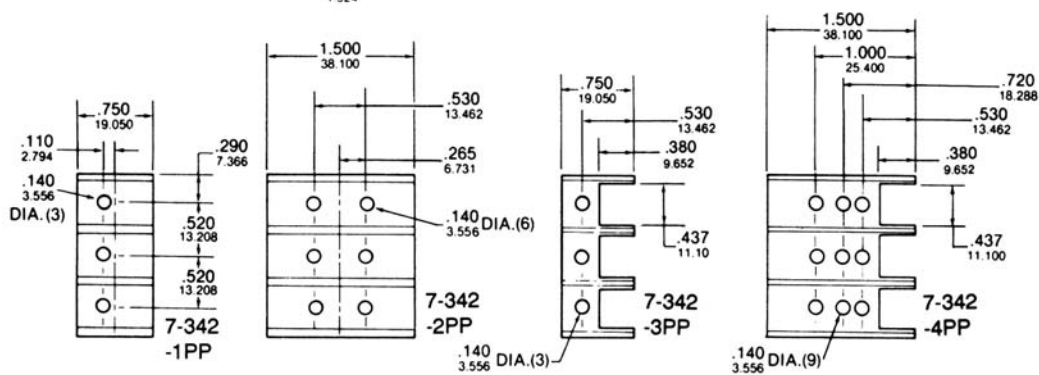
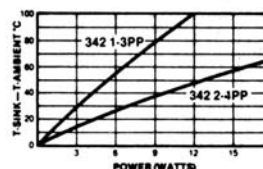

BOARD AND VERTICALLY MOUNTED HEAT SINKS

7-192

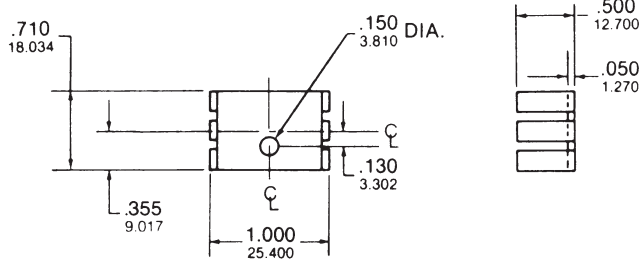
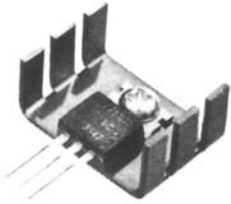

Material... 1100-H14 Aluminum
Finish..... Black Anodize

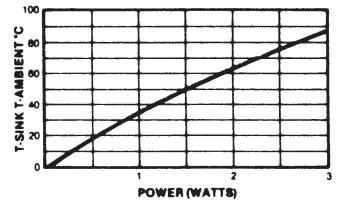

7-361 & 7-362

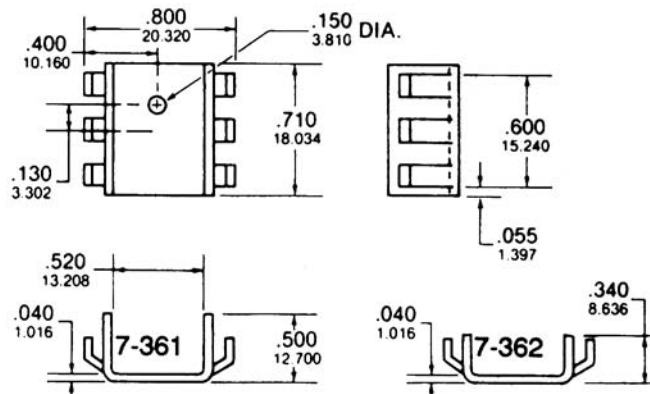
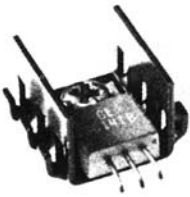

Material... 1100-H14 Aluminum
Finish..... Black Anodize

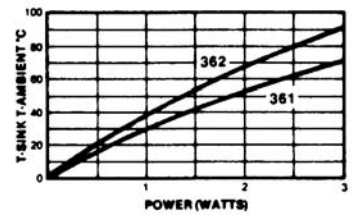

7-371

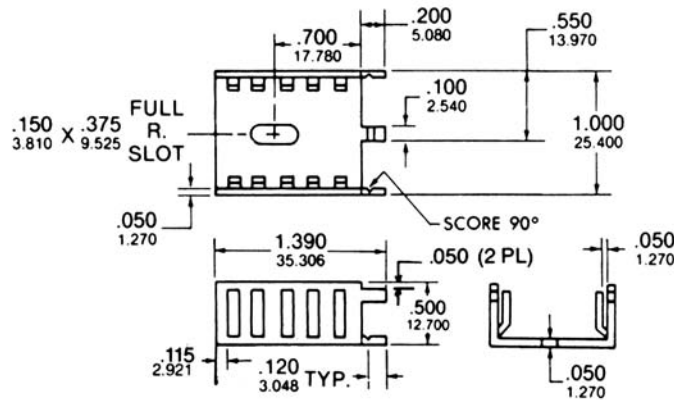
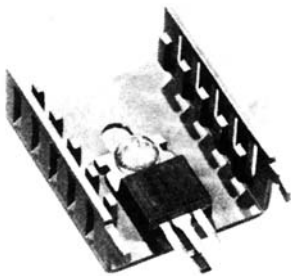

Material... 1100-H14 Aluminum
Finish..... Black Anodize
or Tin Plate

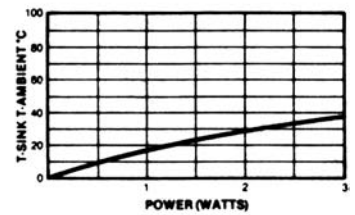

7-370

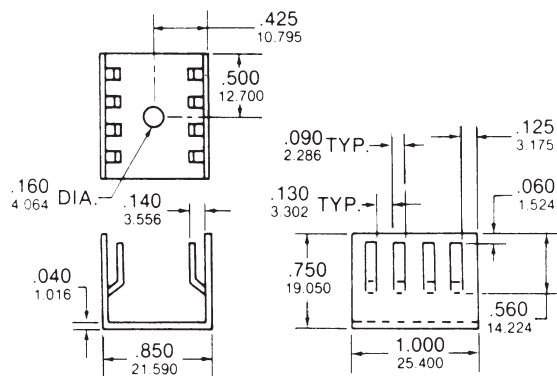

Material... 1100-H14 Aluminum
Finish..... Black Anodize

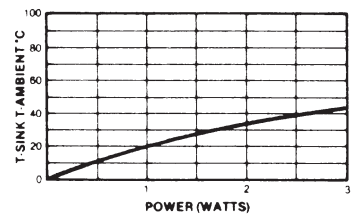

NOTES:

Additional CTS Products Include:

Clock Generator Modules
Synthesizer Modules (VCO/PLL)
Crystal Resonators
Clock Oscillators
Oven Controlled Crystal Oscillators (OCXO)
Temperature Compensated Crystal Oscillators (TCXO)
Voltage Controlled Oscillators (VCO)
Voltage Controlled SAW Oscillators (VCSSO)
Voltage Controlled Crystal Oscillators (VCXO)
Frequency Translator/Jitter Attenuators
DIP Switches
Ceramic Filters
EMC Filters
Potentiometers/Trimmers
Resistor Networks and Chip Arrays
Termination and Bias Networks/ClearOne™

CTS Sales Products are supported by well qualified Manufacturing Representatives and Authorized Stocking Distributors. You may locate your Representative or Preferred Distributor at www.ctscorp.com.

Your CTS Sales Representative is:



CTS Electronic Components

2375 Cabot Drive • Lisle, Illinois 60532
TEL: (630) 577-8800 • FAX: (630) 577-8894 • www.ctscorp.com